

# TK100

- Usage MR(Machine Room)
- Rated Load ~1,600kg(2:1)
- Elevator Speed ~3.0m/s
- Max Shaft Load 10,000kg
- Brake KBD37 DC90V/40V
- Weight 850kg

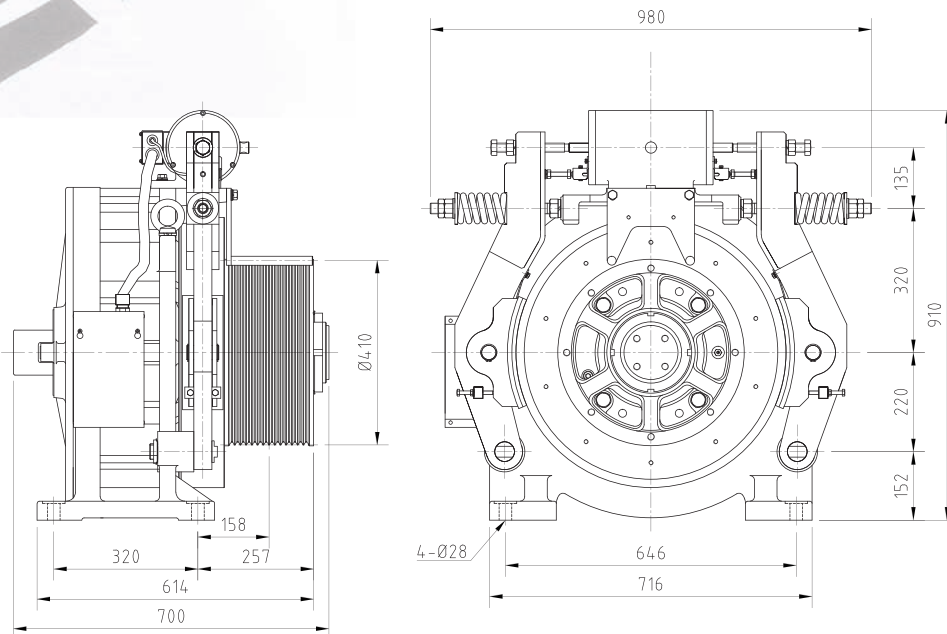

모델명 Model No.	속도 Speed (m/s)	정격하중 Rated load (kg)	시브 직경 Sheave Dia. (mm)	로프경 x 본수 Rope Dia. x QTY (Max.)	출력 Output (kW)	회전수 (rpm)	주파수 Frequency (Hz)	정격토크 Rated Torque (N·m)	정격전압 Voltage (V)	전류 Current (A)	로핑 Ropping	극수 Poles	절연등급 Insulation Class
TK100-083	1.00	1350	410	Φ10x7	8.3	93	24.9	847	234	25.9	2:1	32	F
TK100-124	1.50				12.4	140	37.3	848	215	42.0			
TK100-145	1.75				14.5	163	43.5	846	249	42.0			
TK100-165	2.00				16.5	186	49.7	848	200	59.4			
TK100-207	2.50				20.7	233	62.1	846	249	59.6			
TK100-234	3.00				23.4	280	74.6	799	256	68.7			
TK100-098	1.00	1600	410	Φ10x7	9.8	93	24.9	1004	244	30.7	2:1	32	F
TK100-147	1.50				14.7	140	37.3	1004	223	49.5			
TK100-172	1.75				17.2	163	43.5	1007	259	49.8			
TK100-196	2.00				19.6	186	49.7	1004	209	70.3			
TK100-245	2.50				24.5	233	62.1	1004	259	70.6			
TK100-294	3.00				29.4	280	74.6	1004	280	79.3			